

Sitzbank Bahia

2 Zum Aufbau werden
2 Personen benötigt

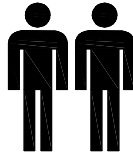

Benötigte
Aufbaufläche
2,5M x 3M

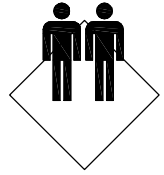

Benötigte Werkzeuge:

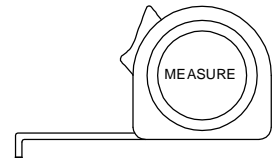
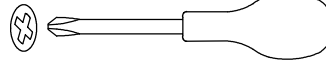
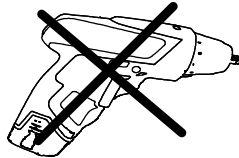

Fertiges Produkt

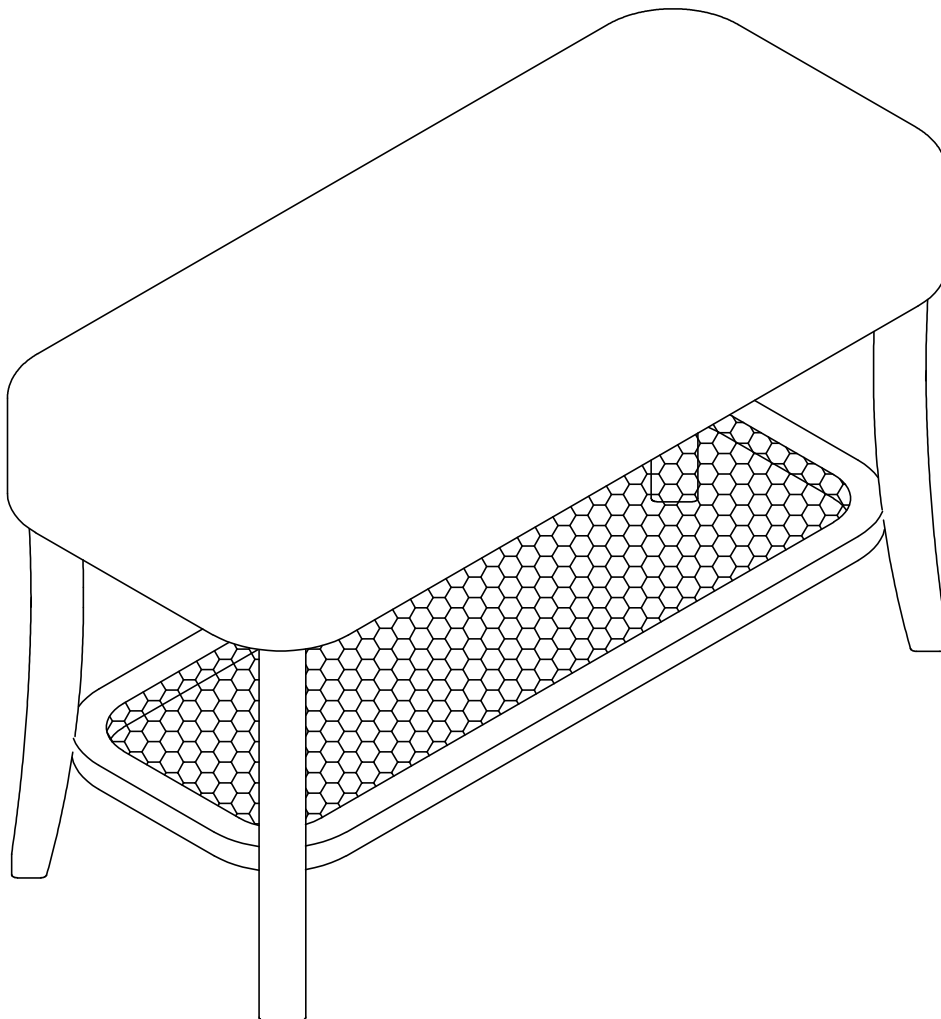

Sitzbank Bahia

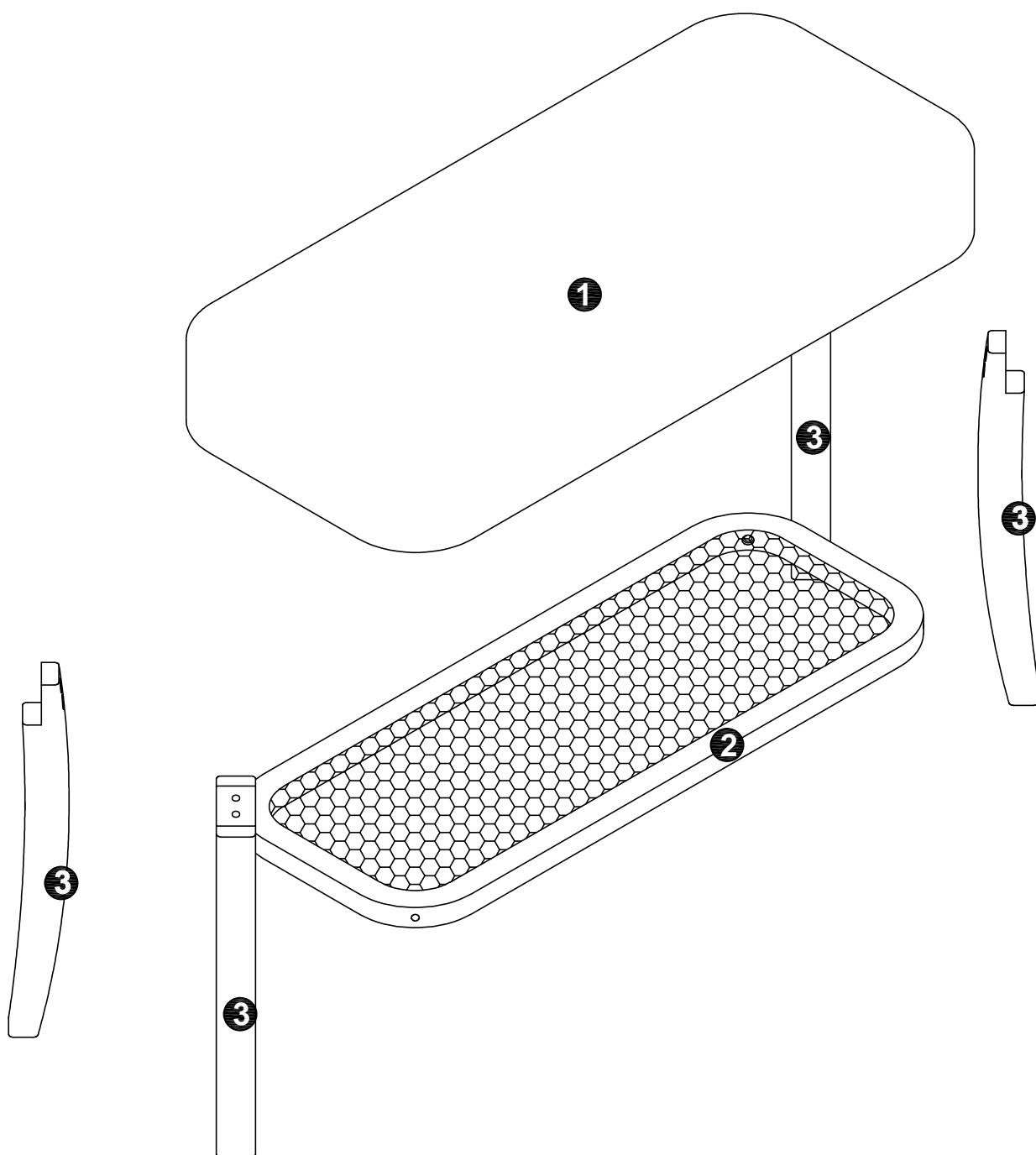

100226

NO.	Stückliste	Menge	NO.	Stückliste	Menge
①	Sitzfläche	1	③	Füße	4
②	Mittelteil	1			

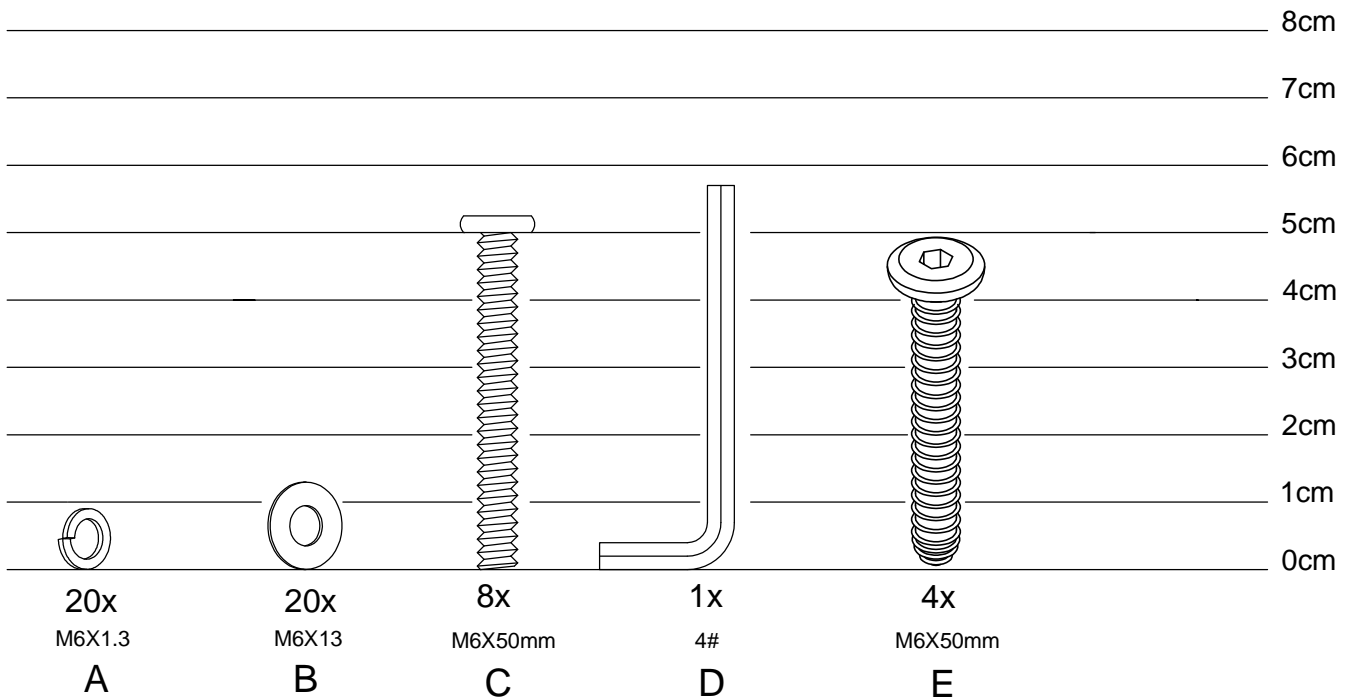

Sitzbank Bahia

Schritt 1

Verwendung von Schneckengewinden und Nockensälen

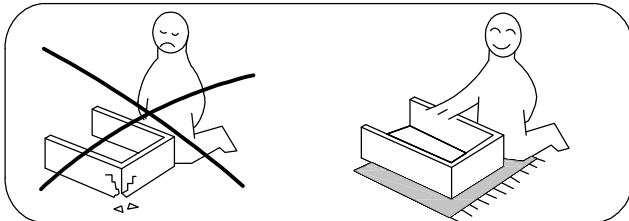
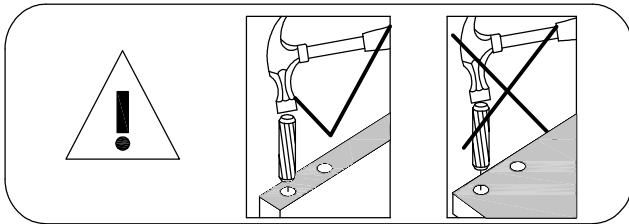
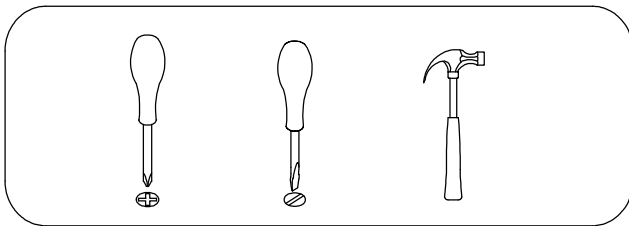

Schneckengewinde



Langen Kreuzarm des Gewindes
an der Schraube ausrichten

Auf korrekte Startposition achten -
Im Uhrzeigersinn befestigen

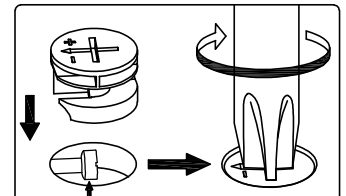
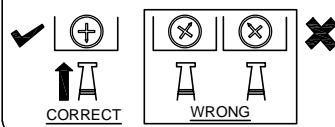

Schraubenkopf muss mittig liegen.

Nockensäle

Befestigen, bis Gewinde
nicht mehr sichtbar ist.

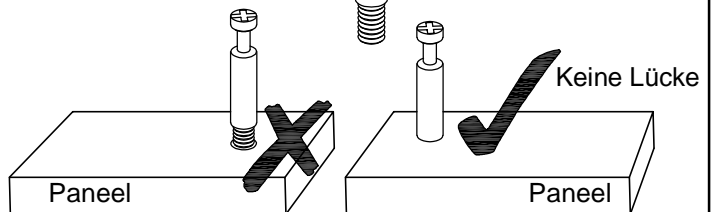

Sitzbank Bahia

Schritt 2

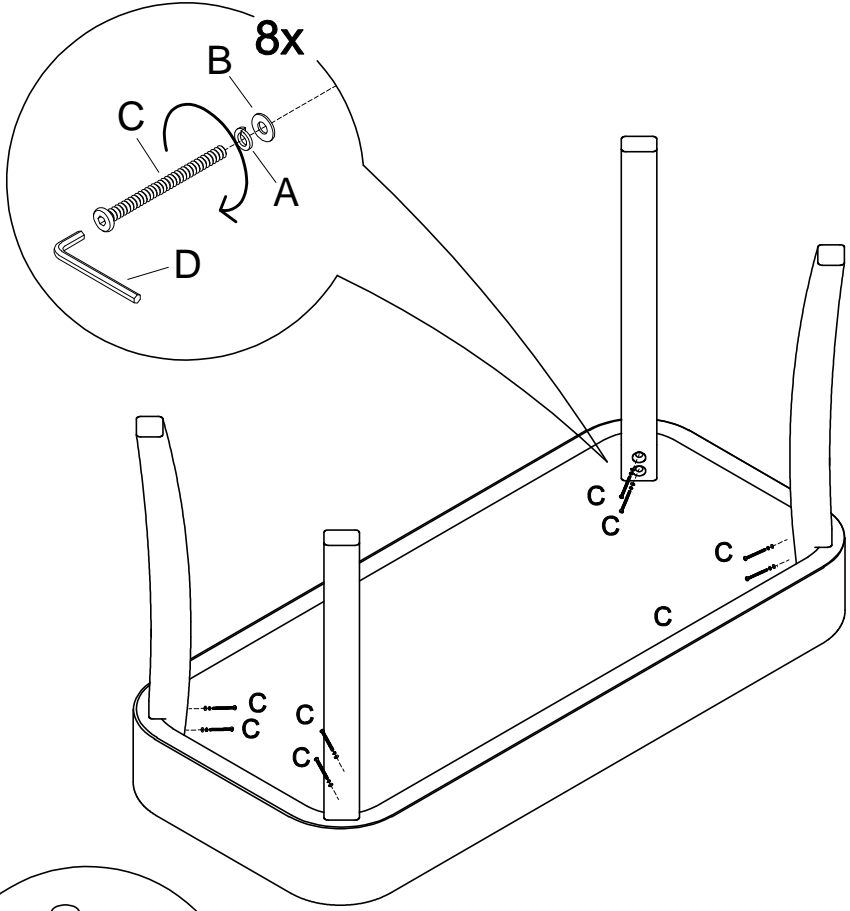

Schritt 3

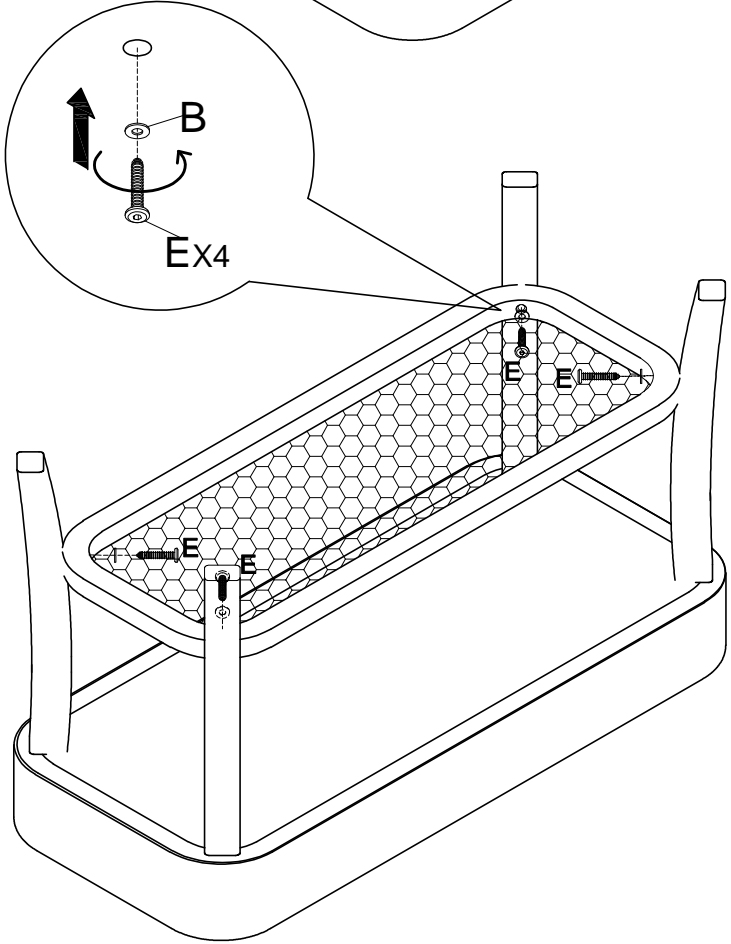

Sitzbank Bahia

Schritt 3

